ONELAN Net-Top-Box (NTB) Systems Overview



1. INTRODUCTION

This document discusses some of the issues that arise when more than one ONELAN Net-Top-Box (NTB) is used in a Network.

The NTB has been designed to deliver a rich functionality when used stand-alone in a Digital Signage application. However, the NTB has also been designed for use in an arbitrarily sized network. Once used in a network, the following additional issues arise:

- ◆ Media and Schedule Distribution.
- ◆ Mixed Administration
- ◆ Network Management.
- ◆ Bandwidth Scalability.
- ◆ Site Accessibility

These issues are discussed in the following sections.

A typical multiple NTB installation is presented in Figure 1 in section 6.

2. MEDIA AND SCHEDULE DISTRIBUTION.

Getting media onto a single NTB is fairly straightforward. The NTB provides a WEB browser based mechanism in its File Manage and Zone PlayList editor Web pages. The NTB also allows the user to make use of the FTP server in the NTB to transfer entire trees of files using an FTP client such as Windows Explorer. Schedules, Layouts and PlayLists are established by using the NTB's various WEB pages.

However distributing Media, Schedules, Layouts and PlayList information to an arbitrarily large network of NTBs is a different matter. To do this 'NTB by NTB' would be onerous and subject to error. The NTB therefore provides a mechanism to do exactly this – **Channel Manager**. See the NTB Channel Manager Guide for further details.

Channel Manager allows the user of a 'Publisher' NTB to design Schedules, Layouts and PlayLists in the usual way and then 'Publish' all required files by clicking a single button. The Publishing NTB then sends a snap-shot of all required files to an FTP file server at a pre-configured location in the attached IP network. This server is formally called the Channel Content Server (CCS). The CCS can be the Publisher NTB itself or more likely an FTP server elsewhere. Once the Publish operation has been completed, the Publisher has no further responsibilities.

3. MIXED ADMINISTRATION.

Even a single NTB is typically administered by more than one person:

- ◆ **Ad-Hoc user.** Typically a receptionist wanting to change simple things such as a welcome message. The key factor here is to make the process as simple as possible.
- ◆ **Media Manager.** An administrator responsible for the look-and-feel of the display and for all media – apart any media delegated to the Ad-Hoc user - above.
- ◆ **The Installer.** The installation engineer responsible for getting the NTB connected to the local network infrastructure and to the output display.

In a network of NTBs, this mixture of administrators becomes even more important. The administrator at the network Head Quarters (HQ) will want to retain overall control but be able to delegate a variable amount of authority to local users. ONELAN formally calls the HQ administrator the **Privileged Administrator**. We call the local administrator the **Subsidiary Administrator**. See Figure 1.

The NTB provides a mechanism to allow the Privileged Administrator to choose at a very fine level, what degree of control to delegate out to the Subsidiary Administrator. The facilities provided are referred to as the **Advanced Ad-Hoc** facilities. These are available as an NTB licensable option. Advanced Ad-Hoc allows the Privileged Administrator to provide default material for all NTBs in the administered Channel but allow local customisation for selected Zones on the output display by the Subsidiary Administrator.

The NTB provides a comprehensive user name and password mechanism to allow multiple Subsidiary Administrators with differing permissions. See the Ad-Hoc Facilities Data Sheet for further details.

The Advanced Ad-Hoc facilities are a separate issue to the Channel Manager facilities (see above) but are often used together.

4. NETWORK MANAGEMENT.

Managing a collection of any network devices brings some challenges – particularly if the devices are scattered over a wide area. This applies to regular network devices such as Router, Switches and Servers as well as 'Network Appliance' devices like the NTB.

Any Network Manager will require a 'visibility tool' to show him/her whether all the appliances are operating normally and whether the intervening Network links are operating. Without Network Management, the operator is running blind and only able to respond to failures rather than being able to correct problems before they are observed by users of the network.

The NTB is a specialized Network Appliance and hence regular Network Management tools (such as HPOpenView) will not give sufficient information about the state of an NTB.

Recognising these points, ONELAN has developed a Windows Application program called the **NTB Status Monitor** (NSM). This software tool presents an 'at-a-glance' view of a very large number of NTBs including the progress of any Channel Manager media transfers underway. See the NSM Data sheet for further details. The NSM is a chargeable Windows application separate from the NTB.

5. BANDWIDTH SCALABILITY.

When administering a single NTB, it is straightforward to estimate the network traffic presented by the NTB. Most material is transferred to the NTB and then played from its local hard disk drive. This is called the 'store-and-forward' method of operation. Some display items may be programmed to be collected from external sources such as RSS News feeds or WEB pages. These typically present very little load because of the compact nature of the data involved. An exception to this may be network video streaming which is now available as an option on the NTB.

However, once a network of NTBs is established (a Channel), distribution of media could present a considerable network load proportional to the size of the network/Channel. The limitations due to Network Bandwidth will be a function of:

- ◆ The size of media files,
- ◆ The number of media files,
- ◆ The frequency of change in the media files,
- ◆ Bandwidth limitations of the source of the transfers,
- ◆ Bandwidth of the intervening network connections.

The Channel Manager facility of the NTB has been deliberately designed to mitigate these issues. The Publisher NTB only has to send the media once to the CCS Server. This keeps traffic associated with multiple Subscribing NTBs off the HQ network.

The overall scalability of the Channel of NTBs is therefore a function of:

- ◆ The CCS. This is typically a service rented from an Internet Service Provider (ISP) or a regular FTP server provided within the organization's IT server facilities. Modern FTP servers are capable of 1000's of simultaneous connections and of providing many 100's of Megabits per second of file transfers.
- ◆ The ability to monitor the required number of NTBs using the NSM. The NSM is essentially a polling application. It polls each configured NTB for status information and presents the results in a tabular/ graphical format. The NSM has been designed to present a very small processing load to its host PC. Multi-threading is used extensively in order to allow a large number of NTBs to be monitored with varying response times. The design target is for the NSM to be able to monitor 1000+ NTBs when hosted on a 3 GHz Pentium P4 class PC.

6. SITE ACCESSIBILITY

A network of NTBs will obviously require connectivity amongst the NTBs, the CCS and the NSM. Some NTBs (possibly located on different sites) will require outbound access, some inbound access and some both for various network protocols.

In a corporate Intranet, all Network Stations will typically be capable of inbound and outbound access. If however, the Channel of NTBs is installed over a Wide Area Network (WAN) it is not unusual to use public Internet based services with restricted access and limited IP addresses. A low cost ADSL service will typically only provide one IP address per subscriber. Some services will not provide a fixed IP address at all. These are more difficult to use.

The Channel Manager and NSM tools have the following requirements:

The HQ Site requires:

- ◆ Outbound access to the CCS for FTP protocol,
- ◆ Read/Write account access on the CCS,
- ◆ Outbound access to all the remote locations for HTTP protocol – if using the NSM,
- ◆ Outbound access to the remote locations for Secure Shell (SSH) protocol – to provide access to the NTBs for exceptional maintenance purposes.

The Remote Sites require:

- ◆ Outbound access to the CCS using FTP, HTTP or HTTPS protocols,
- ◆ Read only account access on the CCS,
- ◆ Inbound access from the NSM for HTTP protocol – if using the NSM,
- ◆ Inbound access from the HQ location for SSH protocol – to provide access to the NTB for exceptional maintenance purposes.

The CCS Site requires:

- ◆ Inbound access for FTP with Read/Write account access,
- ◆ Inbound access for HTTP and HTTPS protocols using the 'GET' HTTP primitive.

It is up to the Network Manager of the organization to ensure appropriate Firewall configurations to enable the above.

If there are multiple NTBs at a remote site, these can be accommodated through a single IP address for the site and using a 'port-mapping' configuration of the site Router. The NTB is able to accept incoming HTTP/TCP calls on up to 10 different port numbers and thereby accommodate port-mapping configurations for up to 10 NTBs at the site.

7. TYPICAL SYSTEM DIAGRAM

Figure 1 describes a typical overall system. The nature of the WAN Infrastructure may well vary with each implementation.

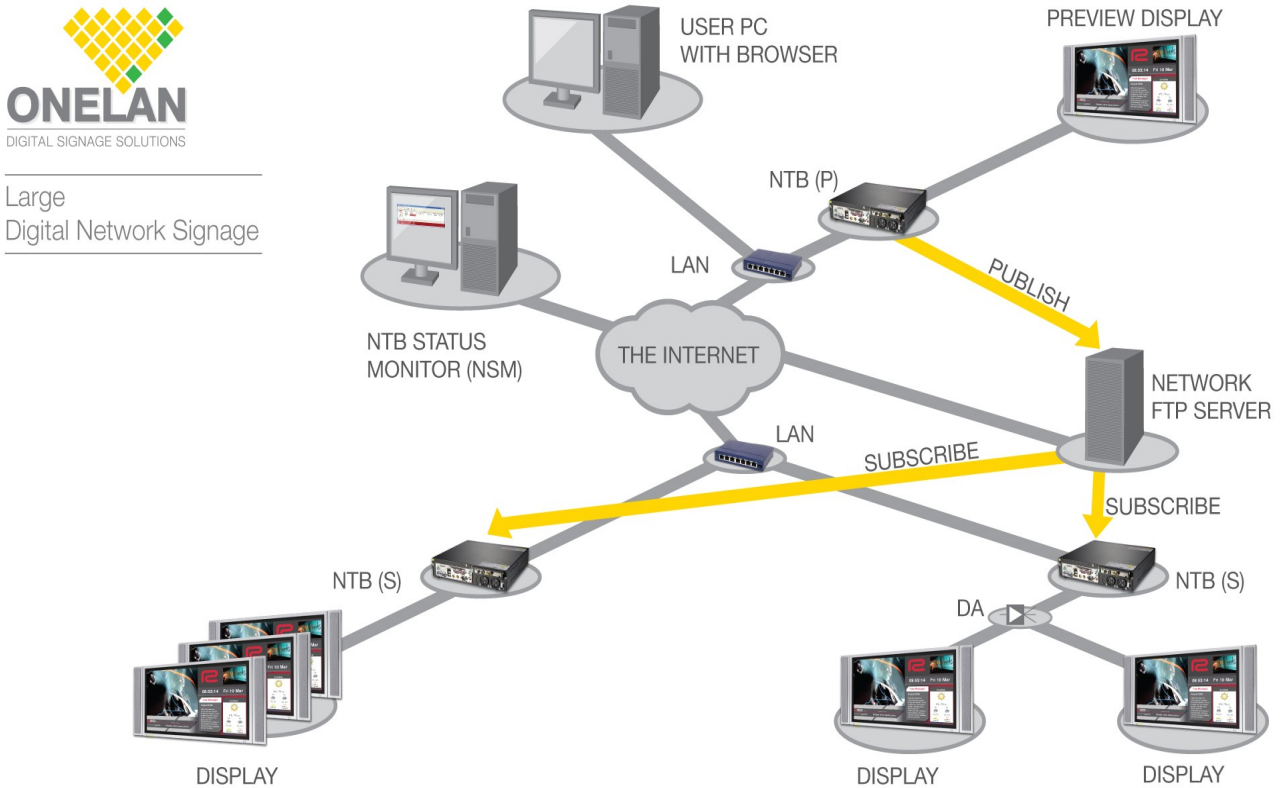

Figure 1 – System Block Diagram

ONELAN LIMITED

Andersen House
Newtown Road
Henley-on-Thames
Oxfordshire RG9 1HG
United Kingdom
Tel: +44 (0) 1491 411400
Fax: +44 (0) 1491 579254
www.onelan.co.uk

Represented by :-



ONELAN reserves the right to alter specification and functionality.

“. NET” is a trademark of Microsoft Inc., Flash is a trademark and licensed product of Macromedia Inc.

NTB SYSTEMS OVERVIEW 22-Nov-07.doc